

*The Original*  
**GALPERTI**<sup>®</sup>  
**ENGINEERING** AND FLOW CONTROL



**DOUBLE BLOCK & BLEED VALVES**  
**BIG SIZES**  
**API 6D - API 600**



[www.afgroup.net.au](http://www.afgroup.net.au)

Project Piping Specialists

**AFF**  
AUSTRALASIAN FITTINGS & FLANGES



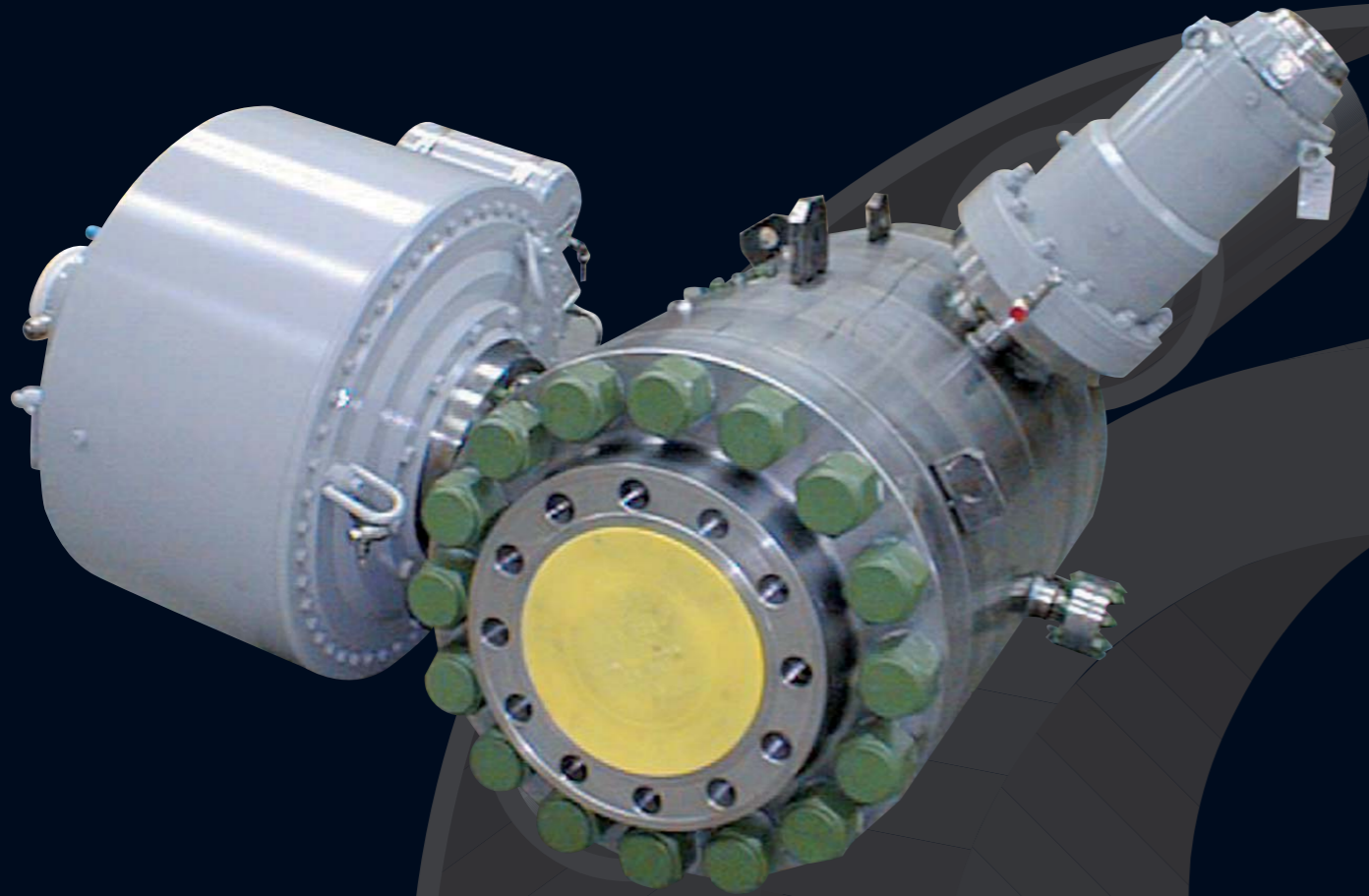

12" 2500# F65  
SUBSEA FULL BORE  
PIGGABLE

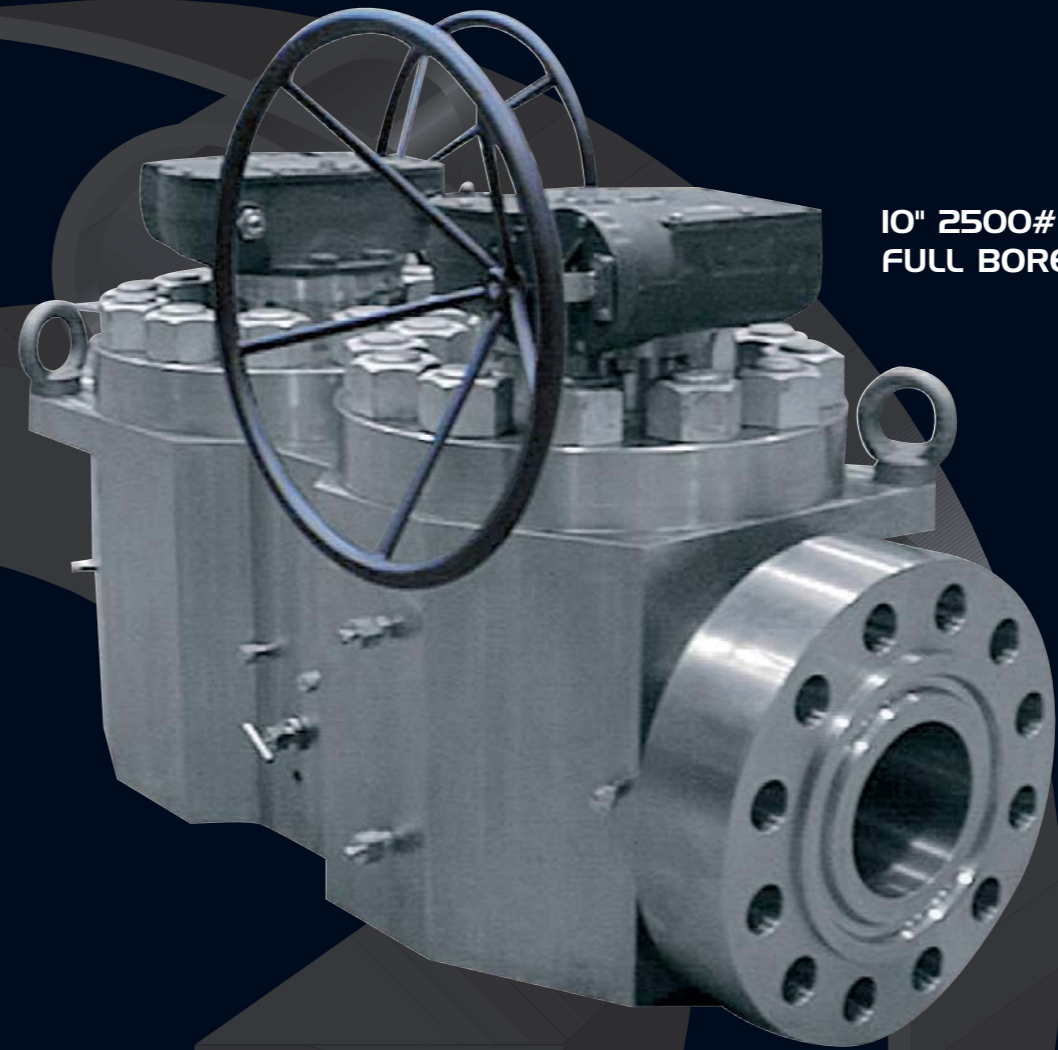

10" 2500# F6NM  
FULL BORE

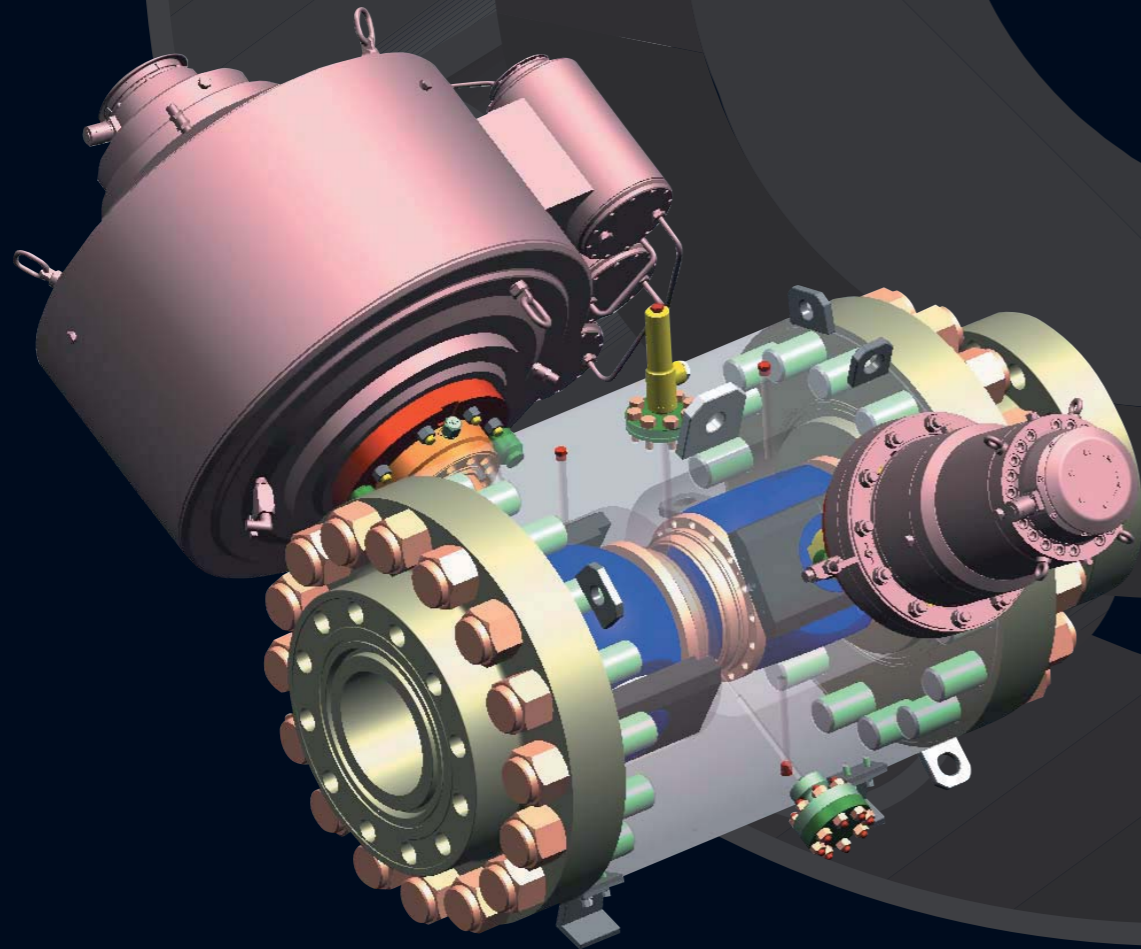

18" 600# A105N  
FULL BORE

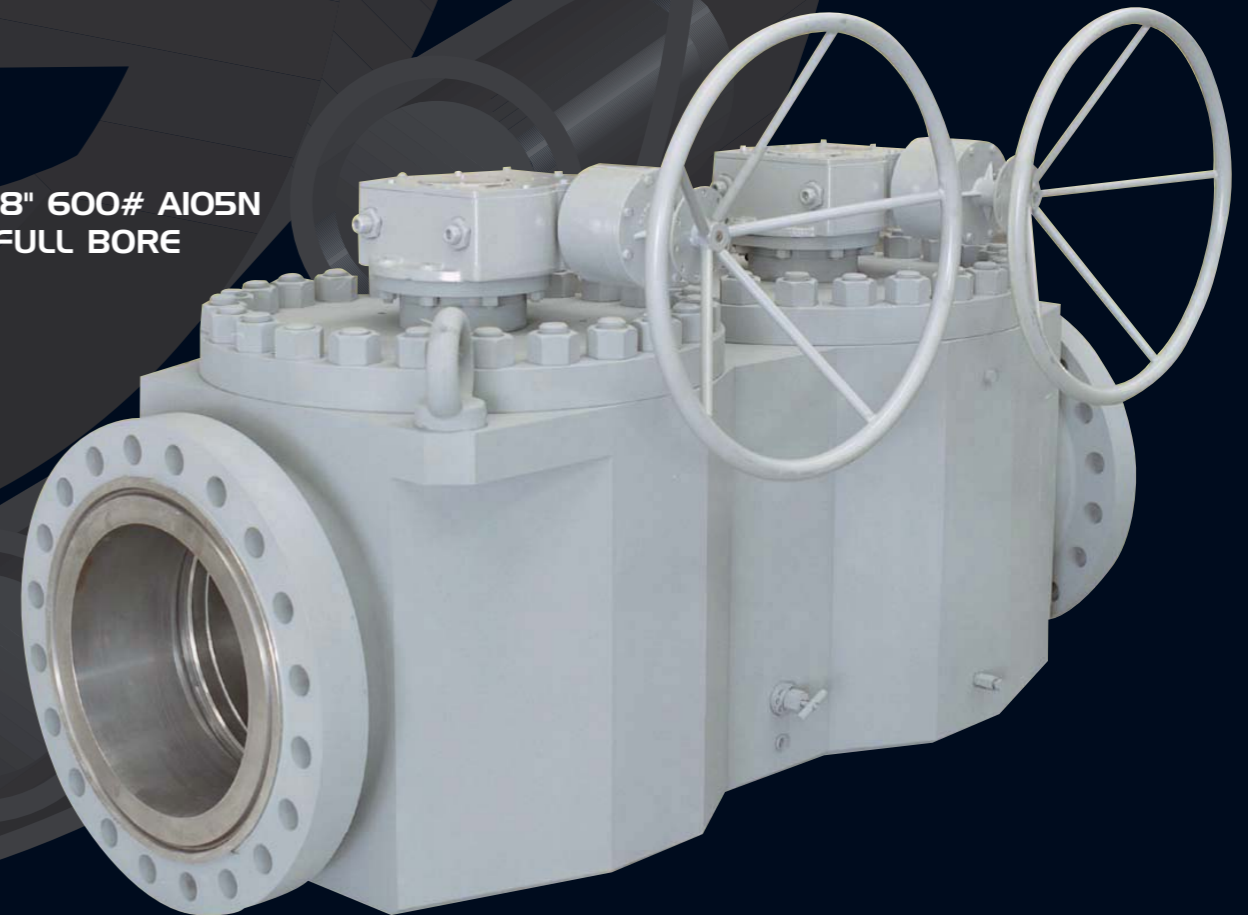



8" X 6" 2500# F51 BALL



6" 600# LF2 BALL



12" 2500# BALL  
INSTALLATION  
IN PROGRESS



GATE VALVES

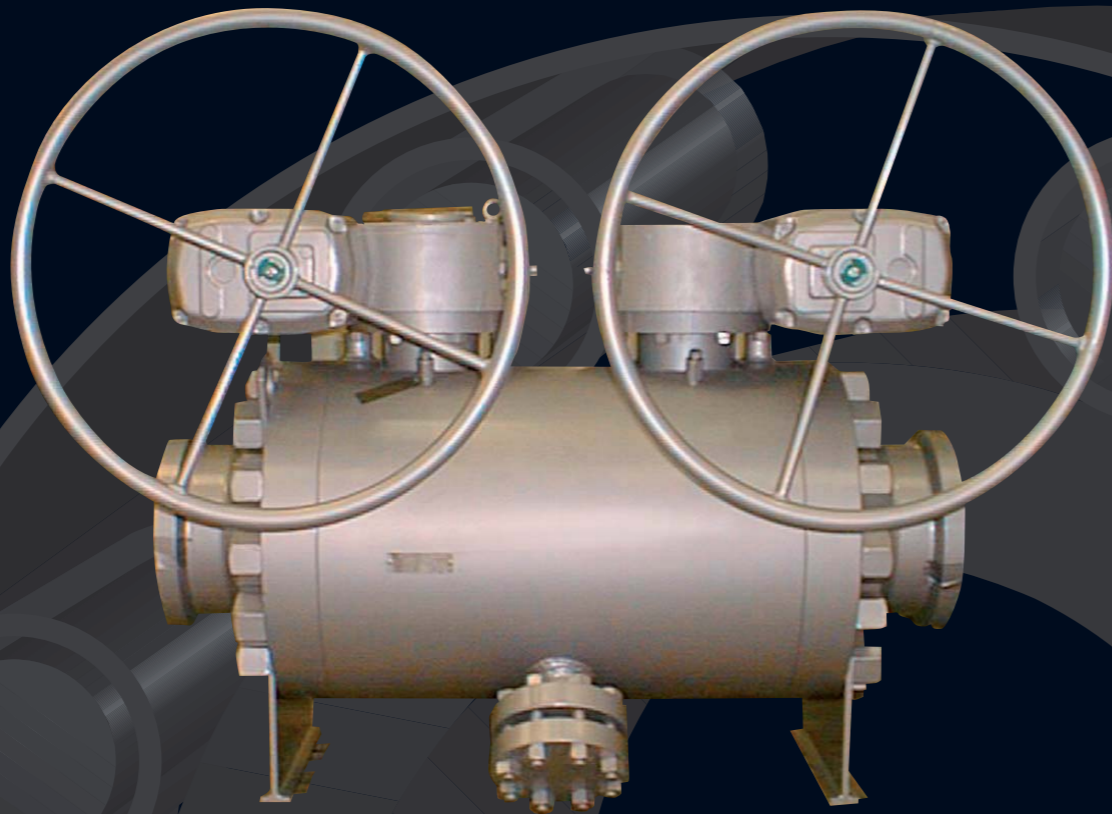

10" 1500# A105N  
FULL BORE

5" 1/8" API  
10,000 PSI 60K  
FULL BORE

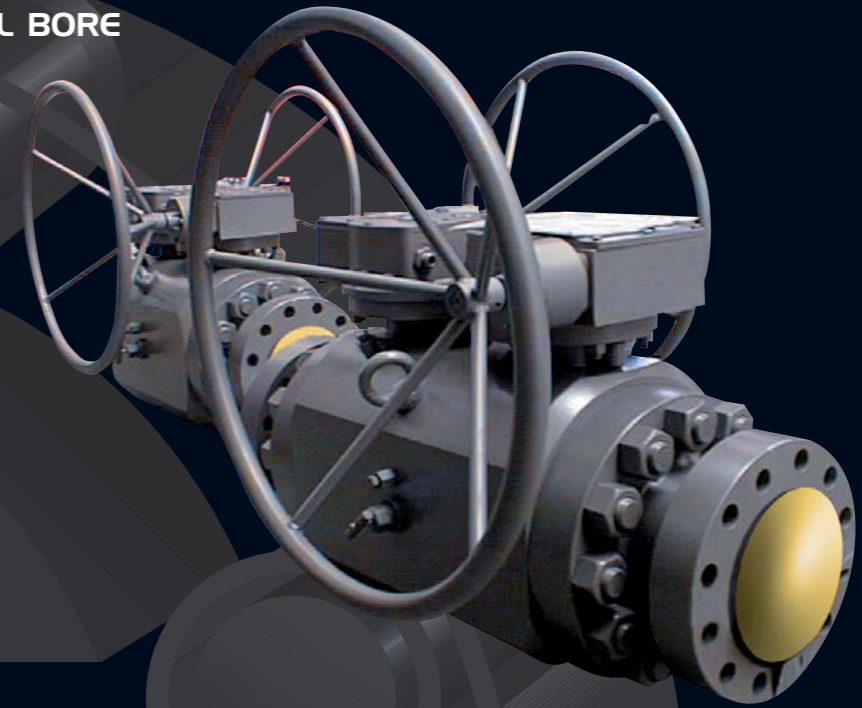

16" 900# F65  
REDUCED BORE



4" 2500# F316  
FULL BORE



4" 2500# F51 GATE  
FULL BORE



3" 2500# INC. 825  
FULL BORE

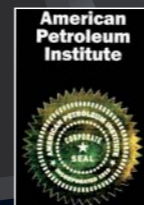

2" 1/16" API  
10.000 PSI  
60K



3" & 4"

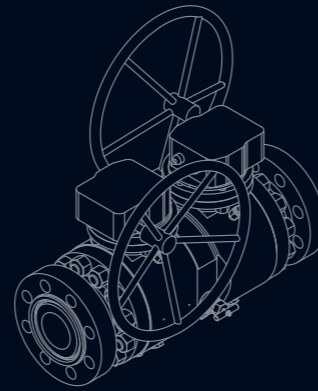

16" X 12"  
1500# F51



≥ 6"

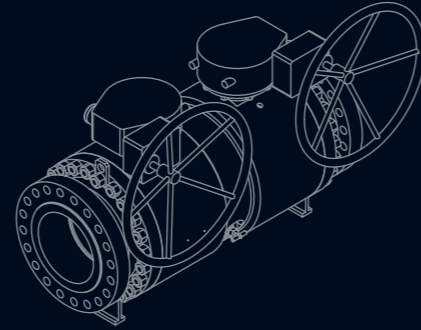

FORGING DEPARTMENT



CNC MACHINING CENTER



CNC LATHE



WELD OVERLAY



3D DIMENSION CHECK



CNC LATHE



FORGING



HEAT TREATMENT



HEAT TREATMENT



HEAT TREATMENT

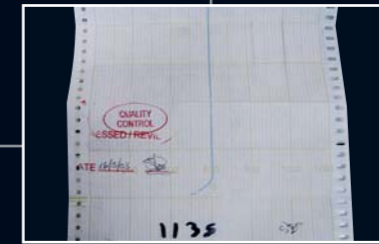

HEAT TREATMENT CHART



ULTRASONIC TEST

Double Block & Bleed Ball Valves Side Entry Trunnion Bolted Bonnet	Class 150#			Class 300#			Class 600#			Class 900#			Class 1500#			Class 2500#								
	Face to Face	Weight	Operator	Face to Face	Weight	Operator	Face to Face	Weight	Operator	Face to Face	Weight	Operator	Face to Face	Weight	Operator	Face to Face	Weight	Operator						
Size In (mm)	RF	RJ	(KG)	RF	RJ	(KG)	RF	RJ	(KG)	RF	RJ	(KG)	RF	RJ	(KG)	RF	RJ	(KG)						
3" (80)	524	537	143	Lever	524	540	146	Lever	584	587	195	Gear	609	612	210	Gear	699	702	272	Gear	816	822	378	Gear
4" (100)	579	592	198	Lever	579	595	246	Gear	691	694	287	Gear	716	719	311	Gear	815	818	413	Gear	938	948	643	Gear
6" (150)	739	752	332	Gear	748	764	371	Gear	904	907	485	Gear	955	958	580	Gear	1040	1046	900	Gear	1304	1317	1629	Gear
8" (200)	839	852	557	Gear	884	900	618	Gear	1042	1045	803	Gear	1119	1122	1100	Gear	1229	1238	1538	Gear	1476	1492	4053	Gear
10" (250)	992	1005	865	Gear	1028	1044	978	Gear	1246	1249	1319	Gear	1311	1314	1734	Gear	1466	1474	2758	Gear	1770	1792	5225	Gear
12" (300)	1135	1148	1387	Gear	1173	1189	1604	Gear	1363	1366	1922	Gear	1509	1512	2632	Gear	1666	1682	4282	Gear	2012	2035	9729	Gear
14" (350)	1259	1272	1795	Gear	1335	1351	1886	Gear	1462	1465	2326	Gear	1598	1608	3004	Gear	1811	1830	5301	Gear	*	*	*	*
16" (400)	1411	1424	2142	Gear	1487	1503	2234	Gear	1640	1643	2784	Gear	1777	1787	3627	Gear	2008	2030	7500	Gear	*	*	*	*
18" (450)	1591	1604	3004	Gear	1641	1657	3132	Gear	1819	1822	3900	Gear	1944	1957	5072	Gear	2216	2238	9890	Gear	*	*	*	*
20" (500)	1717	1730	4028	Gear	1794	1813	4230	Gear	1997	2003	5274	Gear	2121	2134	6849	Gear	2439	2461	13424	Gear	*	*	*	*
22" (550)	1871	1884	4248	Gear	1972	1994	5238	Gear	2175	2185	6537	Gear	2331	2331	9000	Gear	2704	2726	17730	Gear	*	*	*	*
24" (600)	2024	2037	5989	Gear	2100	2122	6282	Gear	2354	2364	7839	Gear	2501	2523	10183	Gear	2926	2954	20162	Gear	*	*	*	*

\* = Please contact the office.

All values given are for general guidance only. For specific applications please contact Galperti Engineering office.  
As part of a process of on-going product development, we reserve the right to amend and change any data of this catalogue without prior notice.  
Note: Bore size according to API 6D - End flanges according to ASME B16.5. Available with compact flanges or G-LOK clamp connector. Dimensions are in mm.

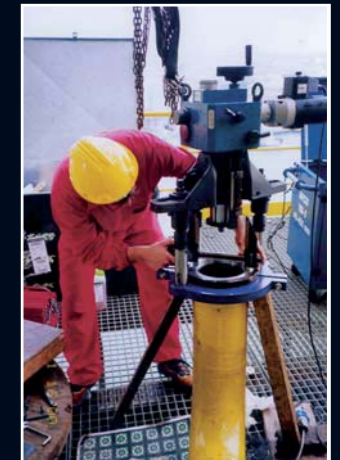
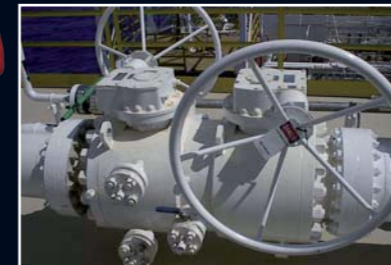

**TEAM SERVICE**

**On site machining 24h service**



**AFF**  
AUSTRALASIAN FITTINGS & FLANGES

Australasian Fittings & Flanges Pty Ltd  
ABN 84 118 519 332  
52 King Edward Road  
Osborne Park Western Australia 6017  
Telephone +61 8 9244 3315  
Facsimile +61 8 9244 3318  
Email sales@affgroup.net.au

[www.affgroup.net.au](http://www.affgroup.net.au)



**OFFICINE NICOLA GALPERTI & FIGLIO S.P.A.**

Loc. S. Agata - 22010 - Gera Lario (CO) Italy  
Tel. +39.0344.97200 - Fax. +39.0344.97210  
[www.galperti.com](http://www.galperti.com) - [galperti@galperti.com](mailto:galperti@galperti.com)



**GALPERTI ENGINEERING  
AND FLOW CONTROL S.P.A.**

Via Prati della Rosa, 17 - 23823 - Colico (LC) Italy  
Tel. +39.0341.930780 - Fax. +39.0341.930777  
[galpeng@galpeng.com](mailto:galpeng@galpeng.com)



**GALPERTI TECH S.R.L.**

Via Prati della Rosa, 30 - 23823 - Colico (LC) Italy  
Tel. +39.0341.930186 - Fax. +39.0341.930252  
[galptech@galptech.com](mailto:galptech@galptech.com)



**GALPERTI INC.**

160 Southbelt Industrial Drive  
HOUSTON, TEXAS 77047  
Phone +1.713.433.0700 - Fax +1.713.433.5580  
[www.galperti-am.com](http://www.galperti-am.com) - [galpmail@galperti-am.com](mailto:galpmail@galperti-am.com)



**GALPERTI MIDDLE EAST Fze**

P.O. Box 17278 - PLOT M0724  
JEBEL-ALI, DUBAI, UNITED ARAB EMIRATES  
Tel. : +9714.8839077 - Fax : +9714.8839070  
[galperti@galperti.ae](mailto:galperti@galperti.ae)

