

GC-COMPACT[®] FLANGE SYSTEM

Proven Excellence, Unmatched Versatility



TRUSTED
SINCE 2006

affgroup.net.au



AFF
AUSTRALASIAN FITTINGS & FLANGES



GLOBAL PLAYER. LOCAL MANAGEMENT.

The Galperti GC-Compact® Flange System has a well established record throughout the world, meeting or exceeding all current industry codes and standards. This lightweight flange system is a fully proven alternative to the conventional flanged connection used globally throughout the Oil & Gas, Chemical, Petrochemical and Power Generation industries. Available in numerous dimensions and materials, it is easy to assemble, metal to metal sealed, corrosion resistant and cost effective.

The GC-Compact® flanges comply with the ANSI, ASME, EN-DIN and API standards and have been widely approved by numerous oil companies and recognised inspection authorities. The reliability of the flanges make them an excellent alternative to conventional ANSI and API flanges, especially for high pressure applications.

Normally with the strength and sealing integrity of a welded joint, the GC-Compact® Flange is lighter, smaller and easier to install than an ANSI raised face or ring joint flange. The main characteristic of the flange is the flange face geometry. It includes a slightly convex bevel (flange face angle) with the highest point called the heel, adjacent to the bore.

During make-up of the connection, the gap at the toe of the flange is closed and flange face to face contact is achieved. The closing of the gap at the flange toe is an indication of correct bolt load has been applied during assembly. Additional bolt tightening cannot over-stress the flanges.

The flange has two seals, one seal, which is activated by the pre-stress, i.e., the heel seal and one self energising and pressure energised seal, i.e. the Galperti Ring (GR) seal ring. This unique double sealing system give superior sealing performance over conventional single sealing designs.

This a high-performance connector achieves extremely high levels of performance by incorporating the most important concepts in piping connector design:

- Seal-seat the smallest possible diameter (to reduce pressure separation loads)
- Dual metal-metal sealing
- Isolate the seal ring from piping loads and internal fluid (to maintain performance under changing conditions).
- Face to face contact after make-up and during normal operation conditions-added strength.

DOUBLE METAL SEALING SYSTEM WITH FLANGE FACE TO FACE CONTACT

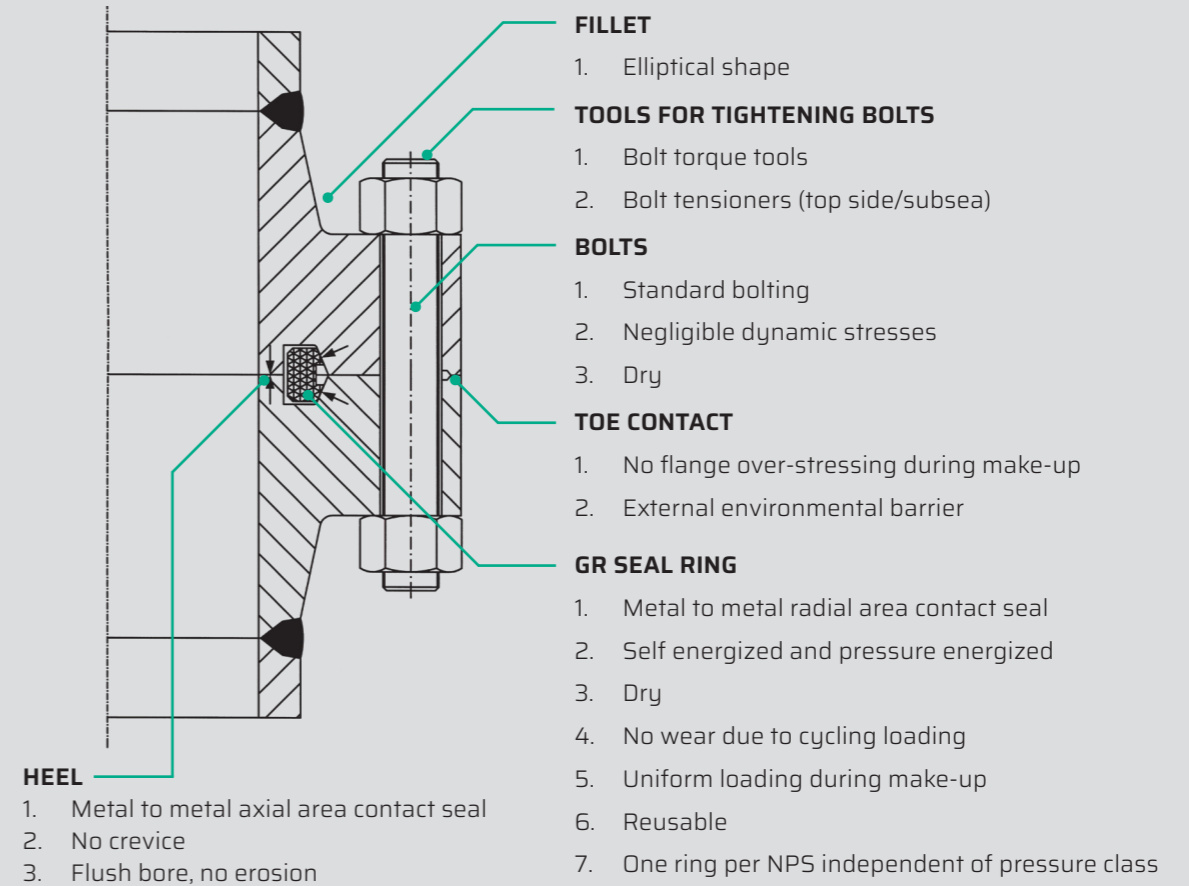

THE OVERALL BENEFITS OF USING THE GC-COMPACT® FLANGE COMPARED TO ANSI FLANGES AND OTHER PIPE CONNECTORS ARE:

- High sealing integrity due to double seals.
- Small dimensions & compact design.
- Much reduced weight.
- Meet ANSI B16.34 valve ends requirements.
- Reusable seal rings.
- One seal ring per NPS (Nominal pipe size).
- Pressure, temperature external load capacities available.
- Standard bolts and tension/torque tools.
- Flush bore with no crevice.
- Full face jointing eliminates opportunity for external corrosion.
- Bolt over-stress cannot damage seal ring or flange.
- Self energised and pressure energised metal to metal area seal ring.
- Maintenance free connection with no periodic re-tightening of bolts.
- Weld overlay welding of sealing area not necessary to bore seal (heel).
- Quick and reliable make-up.



The GC-Compact® Flange uses the Galperti seal ring (GR) which seals in the flange groove. The seal ring design is based on design principles used for the well-established G-Lok seal ring. The heel seal ensures a smooth bore with no crevice between the flange halves at the bore. Furthermore, it reduces the area exposed by pressure to a minimum and keeps the seal ring dry during normal operations.

Compared to other single sealing systems, the heel seal isolates the GR from thermal shocks and corrosion attacks (bore seal carbon steel seal should have included corrosion allowance).

Severe mechanical loads, especially dynamic loads, can render conventional gaskets useless. The GC-Compact®

Flange brings the flange faces into full contact while completely isolating the GR from mechanical loads.

The flange withstands external loads, where loads create yielding in the pipe and separating the flanges while the seal remain leak-free.

All of these concepts allow the GC-Compact® Flange to be more compact and leak-free than standard ANSI/ASME flanges yet still able to meet all of the design requirements in ASME B31.3 and ASME VIII Div. 2. Pressure and temperature ratings are the same as those listed in ASME B16.5 and B16.34.



GLOBAL PLAYER. LOCAL MANAGEMENT.

STANDARD PRESSURE CLASSES, SIZES AND FLANGE TYPES

GC-Compact® Flanges are designed in accordance with international piping and pressure vessel codes.

A full range of GC-Compact® Flanges - equivalent to or with higher rating than ASME flanges are readily available.

The flange covers the usual range of nominal pipe size from 1/2" to 42". It is also available, as standard, in sizes from 26" to 42" for Class 1500, from 14" to 24" for Class 2500 and from 1/2" to 20" for Class 4500.

The flange is available as standard, with the following flange types: weld neck flange, blind flange, swivel flange, integral (equipment) flange, rigid interface and line blanks.

Orifice flanges, restriction orifices and drip rings are also available on request.

MATERIALS

Flanges are available from standard forging with seal ring in compatible high strength material.

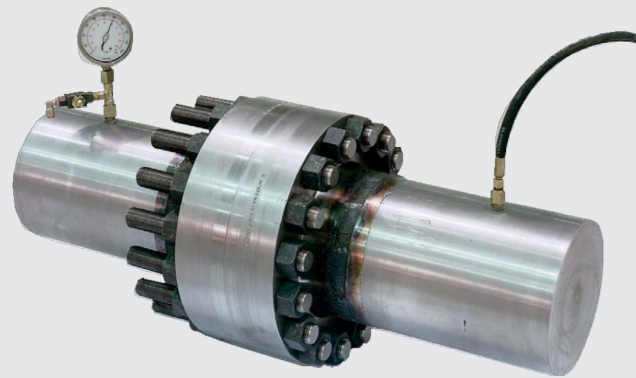

COMPARISON OF A STANDARD ANSI FLANGE AND A GC-COMPACT® FLANGE

Unique sealing system using self energised seal ring.

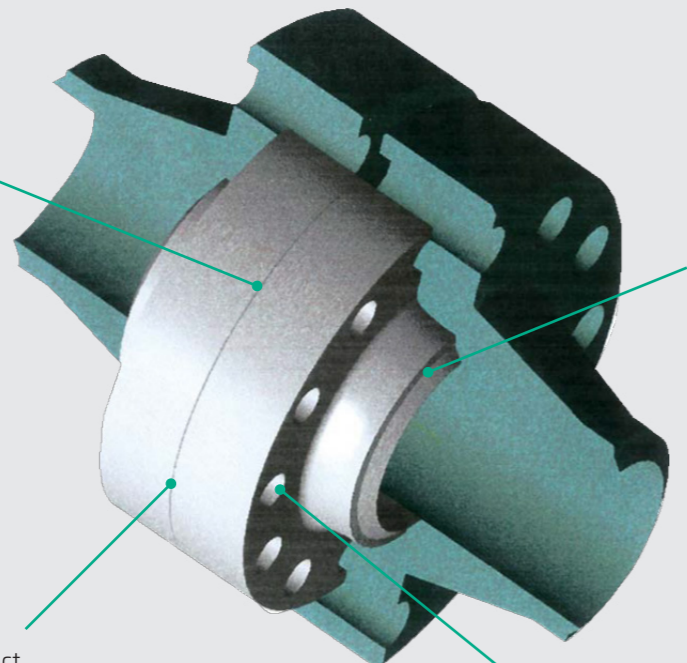

Full face metal contact eliminates external corrosion.

Swivel ring option available to ease lining up and assembly specially in subsea applications.

Smaller, shorter, lighter bolting.

No requirement of special bolting. Use of standard hydraulic bolt tensioner allowed.

APPLICATIONS

The GC-Compact® Flange can be used in many applications throughout a variety of different industries. The many features and benefits of the sealing integrity have gained acceptance in a variety of service conditions. The following is a partial list existing and/or potential service applications.

General: High-pressure, high temperature, hard to hold gas streams, vibrating or pulsating conditions and corrosive service.

Oil & Gas Production: Subsea and onshore pipeline transmission/distribution, flowlines, risers, manifolds, wellheads, injection systems, end fittings.

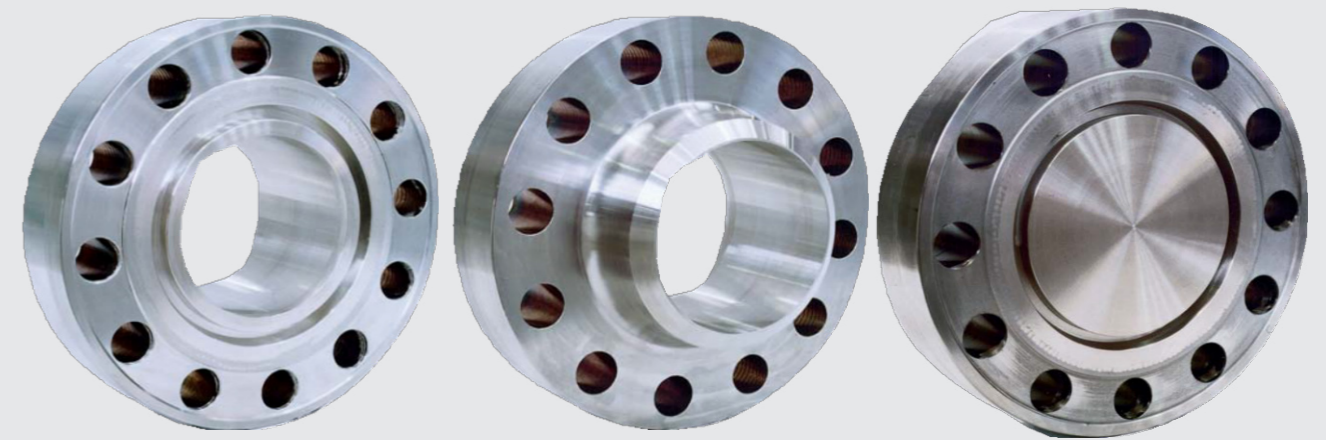

THE ADVANTAGES

Weight/space savings

Industry practice for offshore design suggests a requirement of two kilograms of structure to support one kilogram of deck weight.

Using GC-Compact® Flanges weight savings in the range of 60% to 80% compared to ANSI flanges are achievable.

The flanges are shorter and have smaller diameters than conventional flanges typically 20% to 30% smaller diameters and 25% to 40% shorter connection length when compared to a standard ANSI Flange.

Easy and quick make-up and installation.

The light weight, small size and reduced bolting ensuring ease of handling and assembly.

Reduced connector size leaves more space for the operator and the tooling, and the smaller diameter bolting allows lighter weight tooling to be used. Bolt load up to 100% of desired bolt load first time reduced number of bolting pre-load cycles.

The controlled flange rotation (closing off the gap at the toe) gives a direct indication of correct pre-load.

Utilise standard imperial bolts for straightforward speedy bolting procedures.

Normal off-the-shelf torque and tensioners (topside and subsea) can be used to lighten the bolts up to the desired bolt pre-stress level of minimum 60% of bolt yield stress.

OUR STRENGTHS

Specialised Forged Products: We specialise in customised forged products for demanding applications.

In-House Manufacturing: All manufacturing processes, including forging, heat treatment, machining, and painting, are conducted in-house, ensuring optimal control at every stage.

Specification Compliance: We conduct thorough specification reviews to ensure complete compliance with all requirements.

Quality and Traceability: Our commitment to high quality and superior customer service includes full traceability of materials back to the raw source.

Ongoing Support: We provide ongoing solutions, advice, and recommendations throughout the entire lifespan of your plant.

Global Sourcing: We source superior quality products from globally renowned manufacturers, all of whom are ISO 9001 certified.

Material Selection: Our meticulous material selection process ensures extended facility longevity.

Consistent Delivery: Renowned for our consistent delivery of high-quality products.

Prompt Responses: Rely on us for prompt and precise responses to your inquiries.

Comprehensive Project Management: Our services cover order management, technical queries, documentation, expediting, logistics, and more.

Expert Guidance: Receive expert guidance to ensure accurate installation, maintenance, and sustained functionality.

“Bringing the manufacturer to the client” is the principle that drives our success. AFF offers a comprehensive, globally competitive supply chain, delivering innovative and cost-effective solutions tailored to client specifications. Our goal is to be the preferred supply partner, consistently ensuring that our product quality exceeds client expectations.



Australasian Fittings & Flanges Pty Ltd

ABN 84 118 519 332

8 Wittenberg Drive, Canning Vale 6155 WA

+61 8 6323 8090 | sales@affgroup.net.au

affgroup.net.au

